

AMARRAÇÃO E ANCORAGEM

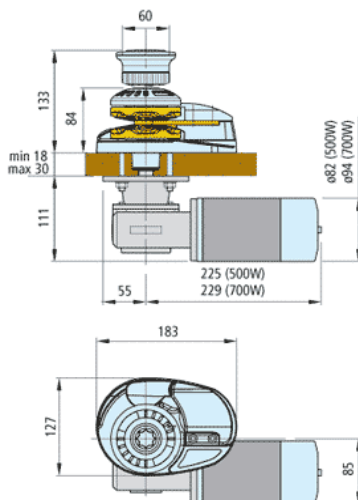

STANDARD

Artigo
Novo



GUINCHO PARA PROA MOD. VERTICAL

Para cabo e corrente

project

X1

Lofrans!
WINDLASSES

MODELO	ELECTRIC MOTOR	GIPSY P/ CORRENTE E CABO	HAULAGE SPEED	CURRENT DRAW	MAXIMUM PULL	WEIGHT
PROJECT X1 BAIXO PERFIL		6 MM				
REF.: 02-0139	500W - 12V	WITH ROPE Ø 12 MM	14-16 MT/MIN	40 - 60 AMPERE	Kg. 550	Kg. 10
PROJECT X1 STANDARD		6 MM				
REF.: 02-0140	500W - 12V	WITH ROPE Ø 12 MM	14-16 MT/MIN	40 - 60 AMPERE	Kg. 550	Kg. 10

GUINCHO PARA PROA MOD. VERTICAL

Para corrente e cabo na mesma roldana. Guinchos com nova tecnologia no que diz respeito a motores, agora mais potentes, continua a ser 1000watts mas se for preciso força extra ele pode chegar até aos 1500watts.

project



STANDARD

X2 1000

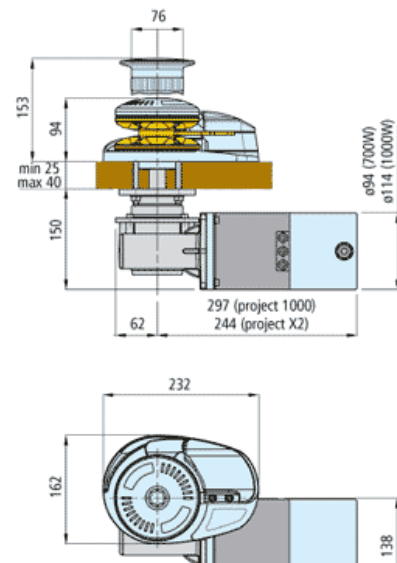

Modelo	Motor eléctrico	Guincho p/ corrente e cabo	Velocidade de recuperação	Corrente	Capacidade de levanta- mento	PESO
PROJECT X2 B.PERFIL REF.: 02-0109 PROJECT X2 STANDARD REF.: 02-0110	1000W - 12/24v	8 - 10 mm Ø8 con cima Ø16 mm	18-24 mt/min	70 - 110 Ampere (12v) 40 - 60 Ampere (24v)	Kg. 950	KG. 20
PROJECT 1000 B.PERFIL REF.: 02-0112 PROJECT 1000 STANDARD REF.: 02-0112	1000W - 12/24v integrado solenoides e conta metros sensor	8 - 10 mm Ø8 con cima Ø16 mm	18-24 mt/min	70 - 110 Ampere (12v) 40 - 60 Ampere (24v)	Kg. 950	KG. 21